



WARNING

Before troubleshooting any CEN products, the service technician should:

- read, understand, and agree to follow all information contained in this troubleshooting guide.
- understand the operational characteristics of the electrical charging system components to be tested.
- be proficient at the use of tools and test equipment used in troubleshooting CEN products.

Hazard Definitions

These terms are used to bring attention to presence of hazards of various risk levels or to important information concerning product life.

WARNING

Indicates presence of hazard(s) that can cause severe personal injury, death, or substantial property damage if ignored.

CAUTION

Indicates presence of hazards that will or can cause minor personal injury or property damage.

Table of Contents

Section A: Description and Operation..... 2
 Section B: Schematic Diagram 3
 Section C: On-Vehicle Troubleshooting 4-5

Tools and Equipment

- Digital Multimeter (DMM)
- Ammeter (digital, inductive)
- Jumper wires
- CEN 6-pin Inline Harness Test Tool A10-114

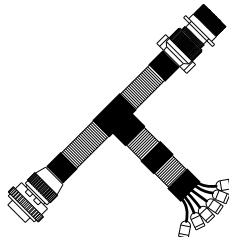

Figure 1—CEN 6-pin Inline Harness Test Tool A10-114

Testing Guidelines

Professional service technicians rely on the following guidelines when testing electrical components.

Voltage testing:

- Set meter to proper scale and type (AC or DC).
- Be sure to zero the meter scale or identify the meter burden by touching meter leads together. Meter burden must be subtracted from final reading obtained.
- Be sure the meter leads touch source area only. Prevent short circuit damage to test leads or source by not allowing meter leads to touch other pins or exposed wires in test area.
- Be sure to use CEN tools designed especially for troubleshooting CEN alternators when available. See page 1 for more information.

Resistance (ohm) testing:

- Set meter to proper scale.
- Be sure to zero the meter scale or identify the meter burden by touching meter leads together. Meter burden must be subtracted from final reading obtained.
- Be sure the meter leads touch source area only. Prevent altering the reading by not allowing fingers or body parts to touch meter leads or source during reading.
- Be sure reading is taken when source is at 70°F. Readings taken at higher temperatures will increase the reading. Conversely, readings taken at lower temperatures will decrease the reading.
- Be sure to test directly at the source. Testing through extended harnesses or cable extensions may increase the reading.

Voltage drop testing:

- Measure voltage between B+ on alternator or source and B- (ground) on alternator or source. Record obtained reading. Move to batteries or other source and measure again between B+ and B- terminals on battery or other source. Difference between the two readings represents voltage lost within the circuit due to but not limited to inadequate cable gage or faulty connections.
- Voltage drop measurements must be taken with all electrical loads or source operating.

Dynamic/Live testing:

Definition: Connecting power and ground to a component to test operation/function out of circuit.

1. Be sure to connect jumper leads directly and securely to source contacts of the component being tested.
2. Be sure to make any connection to power and ground at the power supply or battery source terminals. Do not make connection at component source terminals as that may create an arc and damage component source terminals.



CEN C803D Alternator/Regulator Description and Operation

C803D 28 V, 500 A alternator is internally rectified. All windings and current-transmitting components are non-moving, so there are no brushes or slip rings to wear out. C803D alternator is furnished with an open duct in the anti-drive end cover plate, which accommodates a 4" duct.

This alternator is externally energized when the battery master switch on the vehicle is turned on and provides power to the regulator through the IGN circuit (A2-346 regulator can also operate without vehicle connection to IGN, and instead provide power by sensing rotation through the regulator's AC circuit). Field coil is then energized. AC is rectified into DC output through diodes in anti-drive end rectifier housing and supplied to the battery from the alternator B+ terminal. See Figure 7 on page 3. Alternator output current is self-limiting and will not exceed rated capacity of alternator. Regulator maintains alternator output voltage at pre-determined regulated setting (see below for setpoints) as vehicle electrical loads are switched on and off.

A2-330, A2-336, and A2-361 regulators furnished with some units include:

- External IGN terminal for energize connection.
- (A2-330 & A2-336 only) P terminal that can provide optional AC voltage tap. P terminal signal frequency (Hz) x 10 = alternator shaft rpm.
- (A2-330 & A2-336 only) D+ terminal that can provide DC voltage signal to vehicle electrical system, confirming alternator operation.
- Overvoltage cutout (OVCO) function. See page 4.
- (A2-330 & A2-336 only) Tricolored LED. See page 4.
- (A2-330 only) Current-limiting function.
- Regulator fixed (flat temperature compensation) setpoints shown in Table 1 are selected based on battery type. Battery type selection and battery maintenance/function are the sole responsibilities of the customer.

Voltage Setpoints (± 0.2 V)		Battery Type
Position 1	27.5 V	Maintenance
Position 2	28.0 V	Maintenance
Position 3	28.5 V	Maintenance-free
Position 4	29.0 V	Maintenance-free

Note on Group 31 batteries: If boiling or excessive gassing occurs with high voltage setpoint (position 3), change to medium voltage setpoint (position 2).

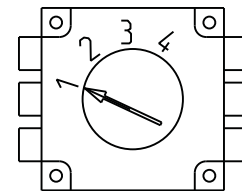

Figure 2—Voltage Setpoints

A2-346 and A2-363 regulators furnished with some units include:

- (A2-346 only) Optional external IGN terminal for energize connection. This regulator can function with or without vehicle ignition. When necessary, IGN terminal on regulator is connected to vehicle ignition to provide battery voltage when engine is running. Circuit should be off (no voltage present) when vehicle ignition is off or engine is not running.
- (A2-346 only) P terminal that can provide optional AC voltage tap. P terminal signal frequency (Hz) x 10 = alternator shaft rpm.
- (A2-346 only) D+ terminal that can provide DC voltage signal to vehicle electrical system, confirming alternator operation.
- (A2-363 only) No external terminals, only a special 3-pin vehicle harness connector providing one pin for optional AC voltage tap (PHASE OUT), one pin for DC voltage signal to vehicle electrical system confirming alternator operation (D+), and one pin for the energize connection (ENG).
- Overvoltage cutout (OVCO). See page 4.
- Tricolored LED. See page 4.
- Battery type selection and battery maintenance/function are the sole responsibilities of the customer.
- J1939 connector to be used with optional A9-4036 harness.
 - When A9-4036 temperature/voltage sense harness is not connected, regulator will operate in fixed voltage setting determined by the select switch position on the bottom of the regulator. See Column 2 in Table 2.
 - When A9-4036 temperature/voltage sense harness is connected, regulator will automatically optimize the charge voltage for battery type based on temperature. Also, vehicle manufacturer-requested functions of 1939 interface are available through connector. See Column 3 in Table 2.

Switch Position	A9-4036 Harness Not Connected (Voltage Select)	A9-4036 Harness Connected (Battery Select)
Position 1	27.5 V	Maintenance (D Category)
Position 2	28.0 V	Maintenance-free (Group 31)
Position 3	28.5 V	AGM
Position 4	29.0 V	DO NOT USE POSITION # 4

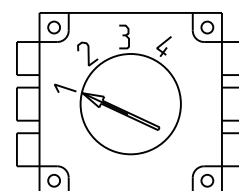

Figure 3—Voltage/Battery Switch



Section B: Schematic Diagram

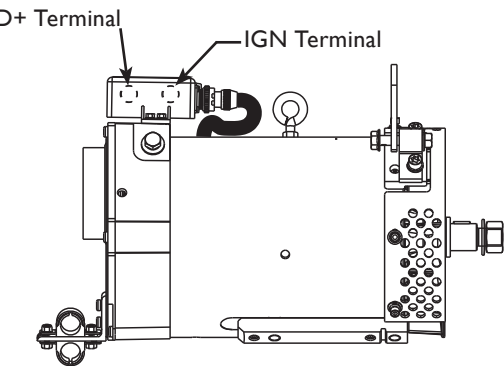
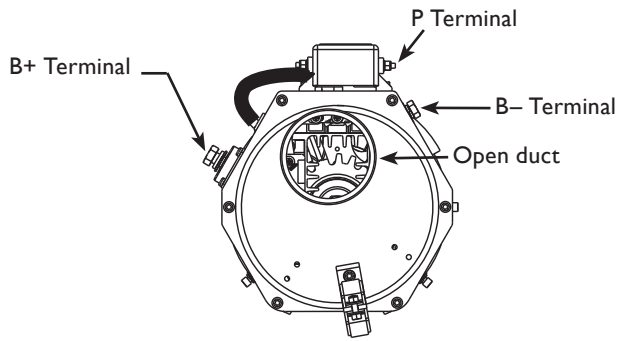

Figure 4 — C803D Alternator and A2-330, A2-336, & A2-346 Regulator Terminals

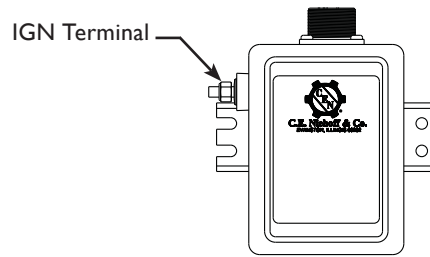

Figure 5 — A2-361 Regulator Terminals

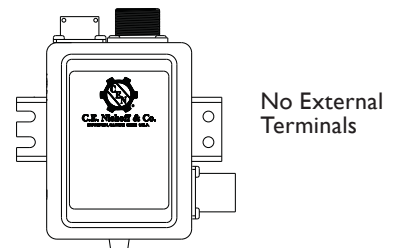

Figure 6 — A2-363 Regulator Terminals

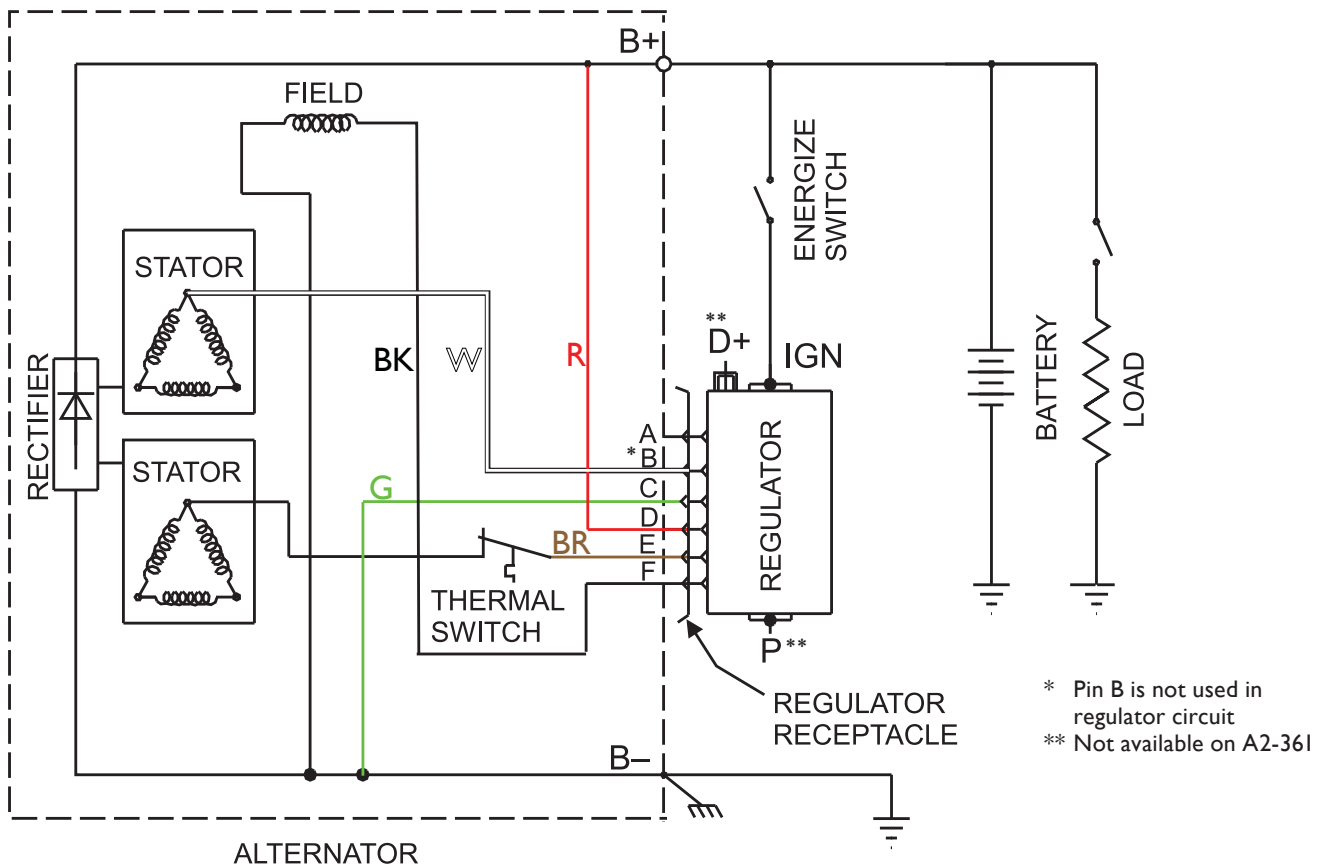

Figure 7 — C803D Alternator Schematic Diagram (A2-330, A2-336 & A2-361 Regulators Shown)



A2-330, A2-336, A2-346, & A2-363 Regulator Troubleshooting

Main diagnostic feature is a tricolored LED next to the harness receptacle on regulator (opposite the alternator-regulator harness receptacle on the A2-346 and A2-363). LED works like a voltmeter, measuring charging voltage. See Table 3 for LED diagnostics.

These regulators have OVCO (overvoltage cutout) that will trip at vehicle electrical system voltage above 33 volts that exists longer than 3 seconds. OVCO feature detects high voltage and reacts by signaling relay in alternator field circuit to open. This turns off alternator (LED is flashing RED). OVCO circuit is reset when engine is restarted (on A2-346/A2-363, OVCO circuit can also optionally reset when system voltage normalizes after 2-minute wait.).

An additional A9-4036 harness may or may not be used with the A2-346 and A2-363 regulators:

- When A9-4036 temperature/voltage sense harness is not connected, regulator will operate in fixed voltage setting determined by the select switch position on the bottom of the regulator.
- When A9-4036 temperature/voltage sense harness is connected, regulator will automatically optimize the charge voltage for battery type based on temperature. Also, vehicle manufacturer-requested functions of 1939 interface are available through connector.

A2-361 Regulator Troubleshooting

This regulator has OVCO (overvoltage cutout) that will trip at vehicle electrical system voltage above 33 volts that exists longer than 3 seconds. OVCO feature detects high voltage and reacts by signaling relay in alternator field circuit to open. This turns off alternator. OVCO circuit is reset when engine is restarted.

General Troubleshooting

OVCO condition

Shut down vehicle and restart engine. If alternator functions normally after restart, a “no output condition” was normal response of voltage regulator to “high voltage” condition. Inspect condition of electrical system, including loose battery cables, both positive and negative. If battery disconnects from system, it could cause “high voltage” condition in electrical system, causing OVCO circuit to trip.

If you have reset alternator once, and electrical system returns to normal charge voltage condition, there may have been a one time, high voltage spike, causing OVCO circuit to trip.

If OVCO circuit repeats cutout a second time in short succession and shuts off alternator field circuit, try third restart. If OVCO circuit repeats cutout, check that pin F in alternator-to-regulator harness is not shorted to B+ terminal on alternator. If it is shorted, alternator is defective. If not, regulator is defective.

No air-conditioning/NO ALT OUTPUT light is on

Some older vehicles may experience a condition when the air-conditioning may drop out during normal vehicle operation. If that should occur, check for regulator setpoint voltage at D+ terminal and 12 V-18 V at P terminal. If present, check vehicle wiring. If not present, check for diode voltage drop between pin E on alternator-to-regulator harness and alternator B+ terminal. If not present, alternator is defective. If present, substitute a known good regulator, run engine, and check for regulator setpoint voltage. If present, original regulator was defective. If not present, go to Chart on page 5.

TABLE 3 – A2-330, A2-336, A2-346, & A2-363 Regulator LED Diagnostics

LED COLOR		STATUS	ACTION
GREEN	Solid	Alternator and regulator operating normally.	No action required.
AMBER	Solid	Low system voltage — Electrical load exceeds alternator rating at present rotor speed.	When loads decrease or speed increases, LED should be solid GREEN. If not, check drive belt and charging system connections.
	Flashing	Alternator fault — No output.	Replace alternator.
RED	Solid	High system voltage – May occur during normal load switching.	Indicates voltage above setpoint but below OVCO threshold (less than 33 volts).
	Flashing	OVCO tripped.	Indicates voltage exceeds 33 V for more than 3 seconds. System diagnosis required. See OVCO condition in “General Troubleshooting” section above.



No Alternator Output – Test Charging Circuit

- TEST MEASUREMENTS ARE TAKEN ON HARNESS PLUG AT ALTERNATOR. TEST MEASUREMENT AT AN EXTENDED HARNESS PLUG MAY AFFECT RESULTS.
- REMOTE-MOUNTED REGULATORS: CHECK CONDITION OF FUSES IN WIRING HARNESS BEFORE TROUBLESHOOTING.
- BEFORE STARTING DIAGNOSTIC SEQUENCE, VERIFY THE FOLLOWING AND REPAIR/REPLACE IF NOT TO SPEC:
 - BATTERIES FOR STATE-OF-CHARGE (24.5-25.5 V), CONDITION, AND SECURE CONNECTIONS
 - MASTER BATTERY SWITCH FOR FUNCTION

MASTER BATTERY SWITCH ON, KEY ON, ENGINE ON: Test for battery voltage at B+ terminal on alternator to ground, then at IGN terminal on regulator to ground (A2-363: unplug 3-pin harness plug and test pin C [Eng] at plug to ground; A2-341 regulator: See page 2 for more information). Does battery voltage exist at both locations?

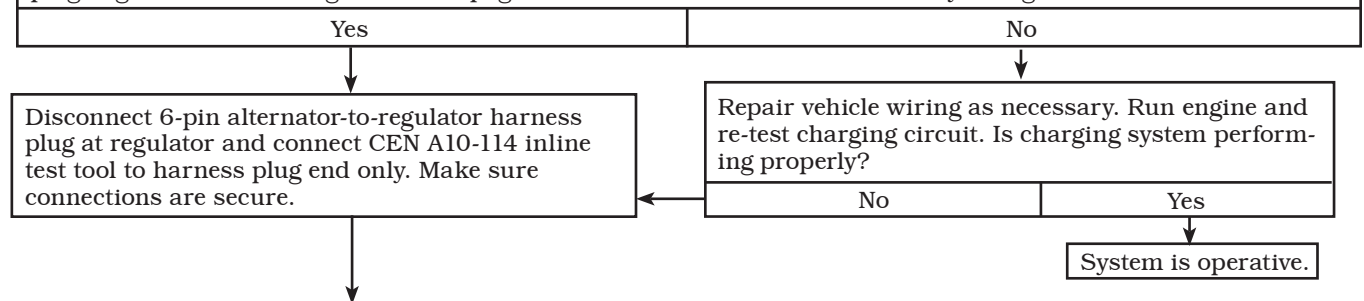

MASTER BATTERY SWITCH ON, KEY ON, ENGINE OFF: Readings of all four tests must pass.

1. Battery voltage test: Connect DMM red lead to socket D in test tool. Connect DMM black lead to socket C in test tool. Battery voltage should exist.
2. Field coil resistance test: Set DMM on Ohms test. Field resistance between sockets F and C in test tool should measure nominal $1.0-1.5 \pm 0.2$ ohms. Field coil is defective if reading is less than 0.5 ohms or greater than 3 ohms.
3. Significant magnetism test:
 - a. Securely connect one end of a jumper wire to socket F in test tool.
 - b. Momentarily (1 sec.) touch other end of jumper wire to alternator B+ terminal. Spark will occur at B+ terminal. Touch steel tool to shaft to detect significant magnetism.
4. Phase supply test: Set DMM to diode test. Connect DMM black lead to socket E in test tool. Connect red lead to alternator B+ terminal. DMM should read blocking in this direction. Then reverse leads. DMM should read flow in this direction. Repeat for socket E and B- terminal. Tests should read flow in one direction and blocking in the other direction.

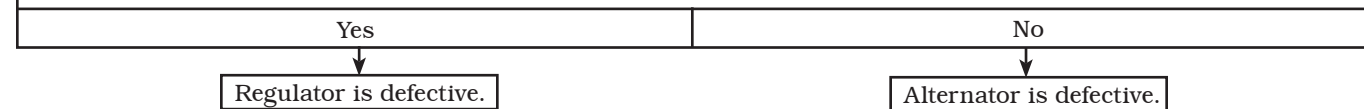

SOCKET CONNECTIONS

- Socket A Not used
- Socket B Not used
- Socket C B-
- Socket D B+
- Socket E Phase
- Socket F F+

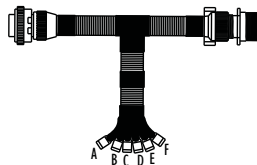

Figure 8 – CEN 6-pin A10-114 Inline Harness Tool Socket Connections

PIN CONNECTIONS

- Pin A D+
- Pin B Phase out
- Pin C Eng

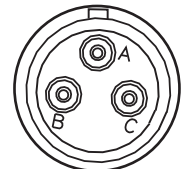

Figure 9 – A2-363 3-pin Harness Pin Connections

If you have questions about your alternator or any of these instructions, or if you need to locate a Factory Authorized Service Dealer, please contact us at:

C. E. Niehoff & Co. • 2021 Lee Street • Evanston, IL 60202 USA

TEL: 800.643.4633 USA and Canada • TEL: 847.866.6030 outside USA and Canada • FAX: 847.492.1242