



**C.E. Niehoff & Co.**  
**BRUSHLESS ALTERNATORS**

**C326**  
**28 volt**  
**140 amp**

## **DESIGNING FOR TOMORROW'S DEMANDS**

### **ALTERNATOR FEATURES**

#### **Air Cooled**

Eliminates the need for an oil or water circulation system. No possibility of leaks, no hoses, and no waste heat transferred to the engine.

#### **High Efficiency**

High Efficiency means lower internal alternator operating temperature, resulting in longer alternator life. Less engine power needed to produce electric power means more engine power available for other needs.

#### **Unique Brushless Construction**

Elimination of rotating windings, brushes and slip rings yields durability, extends service life, eliminates arcing and reduces electromagnetic interference. (EMI)

#### **Long Life Bearings**

Special bearings system designed for extended service life in hot engine compartments.

#### **Conformal Coating**

Protects regulator and rectifier against damage from vibration and corrosion.

#### **High Temperature Insulation and Coating**

Increases durability in hot engine compartments; seals out moisture and protects against corrosion.

#### **Regulator Features\***

Model has R and D+ terminals to supply status to vehicle monitoring system.

Soft start protection

Overtoltage protection

Smart regulators

High reliability "Military Style" connectors

100% protected

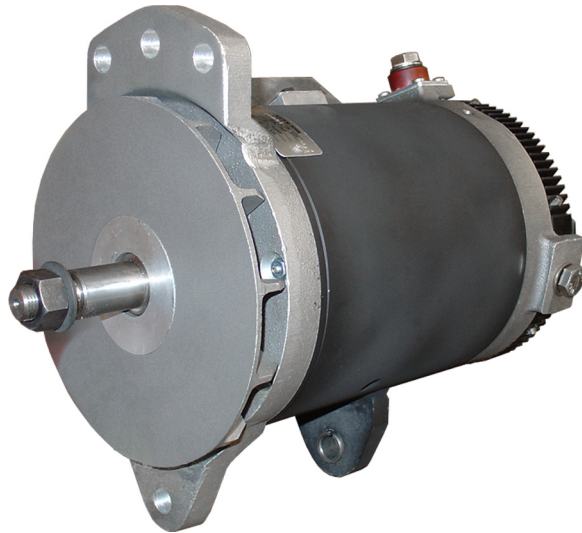

### **PERFORMANCE CURVES**

The measurements listed on the curves are taken at the listed ambient temperatures with a stabilized machine temperature, as per SAE J56. The shaded area highlights output available at typical engine idle alternator speed.

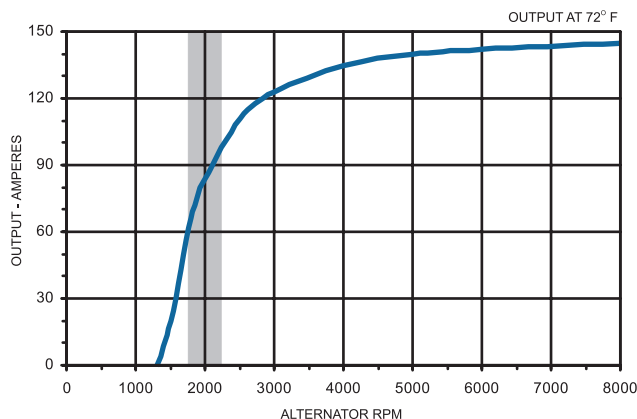

\*For select regulators

**C326**



**C326**  
**28 volt**  
**140 amp**

### DIMENSIONS

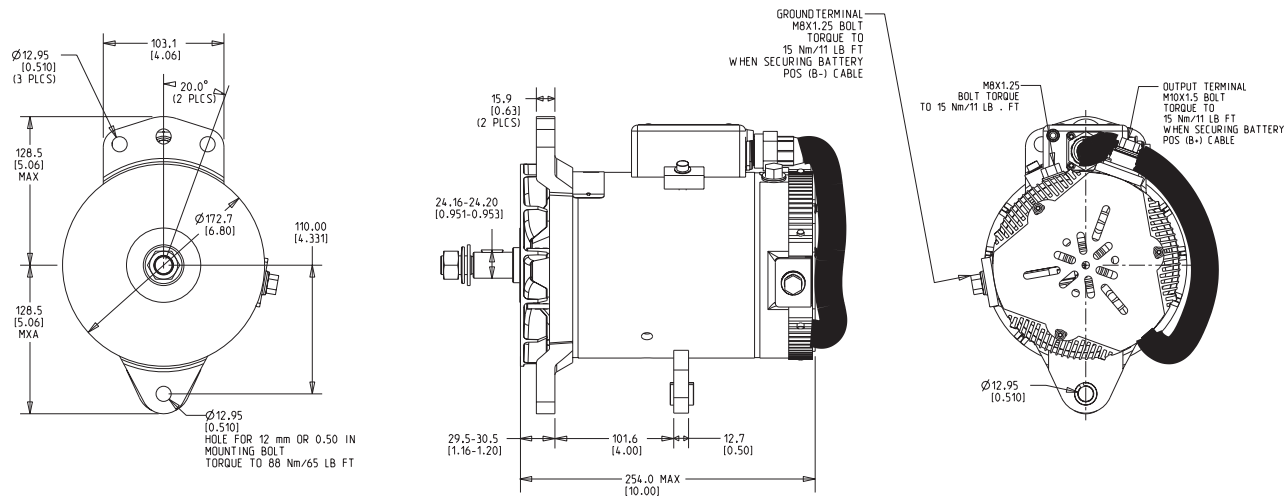

Linear Measure mm [IN]

### HORSEPOWER AND EFFICIENCY CURVES

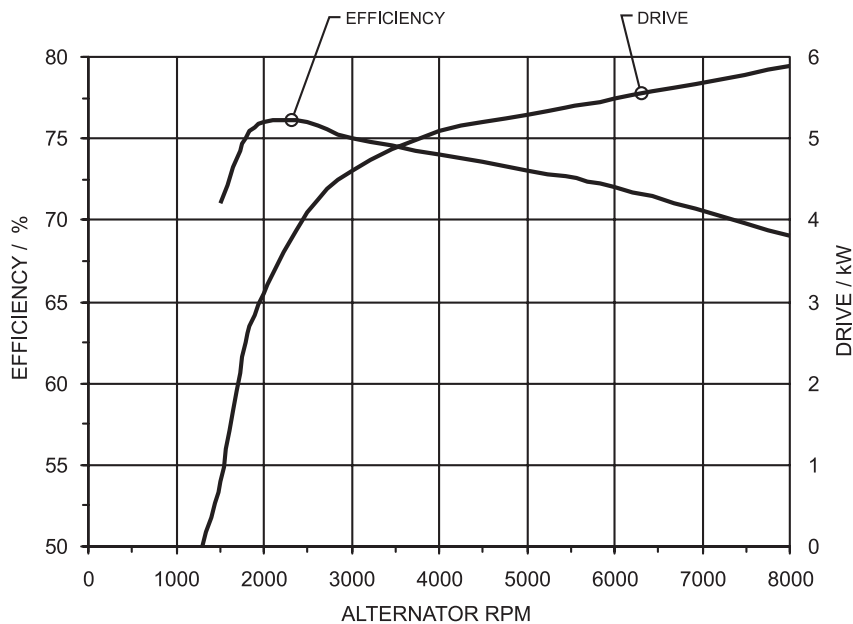

**C.E. Niehoff & Co.**



2021 Lee St • Evanston, IL 60202  
 Phone: 847-866-6030 • Fax: 847-492-1242  
 sales@ceniehoff.com • www.ceniehoff.com

SS-0810

**C326**